

Issue Number Sixty Two

Second Quarter 2011

OFFICIAL JOURNAL OF THE COLLINS COLLECTORS ASSOCIATION

## Join Us on the Air!



- Sunday 14.263 mHz at 2000Z
- Tuesday 3805 kHz at 8pm CST
- Thursday 3805 kHz at 8pm CST
- Friday (West Coast) 3895 kHz at 10pm CST
- Sunday 10m AM 29.050 mHz at Noon CST
- 1<sup>st</sup> Wednesday AM 3880 kHz at 8pm CST

Sunday for Technical, Buy, Sell & Swap  
Tues., Thurs., Fri., & Sunday for Ragchew

## Understanding Your AGC and S Meter - In Four Parts

Introduction by Bill Carns N7OTQ

### Inside This Issue

Understanding Your AGC and S-Meter - A Series	1
From the Editors' Desk	2
Dayton & Dallas - The Reports	2
Dayton 2011 Hamvention A Great Time	3
Dallas 2011 Ham Comm	14
Remembering CCA SKs	15
From the President	16

Visit the CCA Website

[www.collinsradio.org](http://www.collinsradio.org)

See our new features.

You can also renew your membership on line via our website and the PayPal link.

### In the News

- CCA Holds New Dallas Ham-Com Event in 2011
- Read all about it—Dayton Hamvention Success
- AGC for Dummies
- SK Remembrance



## From the Editor's Desk

by Bill Carns, N7OTQ and Co-Editor Joe Nyberg, WILJN

What a quarter. Actually I ought to say, what a quarter and a half, I am so late with this. I have already said this in the President's Column, but I want to repeat it here. Following Dayton, I had the misfortune to catch a terrible case of flu which turned into a severe bronchial infection. That turned out to be drug resistant and I still am getting over it a month and a half later. Needless to say, not much has gotten done here. I have not been able to get on the nets, which you know I love, and I am way behind with everything in my life. Several other folks that went to Dayton got this too with similar recovery times.

I am not making excuses because you know that I often run late with this effort here. I don't know why that is, because it is not my nature to be late, but here I am. Thank you all for your patience and we will try and get back on track. This issue particularly has been like pulling teeth. Everything that could go wrong, has. But, by the time you read this, it will all be history and I will be on vacation.

We are fortunate this quarter to have Don Jackson writing for the Signal again. I always enjoy his technical articles and I know that you do too, since I consistently get good comments on his work. This article is the start of a series which will address a common area of reflector queries and confusion. AGC and S meter performance, and adjustment, is often the source of misunderstanding. Hopefully this series of articles

will help clear some of this up.

During the last several months, I have been associated with working on several big Collins transmitters, or amplifiers. Scott Johnson (W7SVJ) and I have discovered a very interesting aging effect in the high voltage area of these boxes. This defect - that develops with age and use - is really (with 20-20 hind sight) a design problem, but who could have predicted it 50 years ago. There will be a nice article on that subject coming up soon. We will provide you with this information as soon as the work is finished and can be written up.

The stories here on Dayton and Dallas are really not to my liking. We had good photography coverage on the Dayton Banquet on Friday night, but we did not have a good working camera - it turns out. So, we have very little in the way of photos and the ones we have are poor. I am sorry. I particularly want to apologize to our guest speaker, Jim Macanni, WOHUP. Jim, that photo is the sole survivor. We sure did enjoy the talk though. For those of you that could not attend, Jim was the former head of the KWM/HF 380 Customer Service Group at Collins Radio and gave a great talk on the changes and features on that rig.

This issue, I have finally come to grips with a sad issue that has been, in retrospect, causing me to procrastinate on a number of listings of SK announcements. The entire subject always saddens me, but this past year has been tough. It started almost a year ago with the sudden and

## Dayton & Dallas are behind us & What a Great Time

Dayton 2011 is now written in history, and by all accounts it was a good one. I have not attended every Dayton Hamvention, but I have been going on and off for the last 20 years, maybe 25. Lately, since becoming the Signal editor, I have been going every year. You often hear people saying that there is less and less old boat anchor tube gear there, and that the end is near. Well, I can tell you that this year was a big change and that Dayton is alive and well.

The CCA has long held its annual get-together at the Dayton Hamvention and, in fact, our gatherings have continued to get bigger and bigger over the years, as the organization has grown. This year was no exception.

**Dallas:** In addition to Dayton, on the weekend of June 10, as promised, the CCA extended its gatherings to include Dallas Ham Comm for 2011. The first year was a winner. Although we started small with room for just 25 folks at dinner on Friday night, we had a full house and it will be bigger next year for sure. The wonderful part of the evening is that we had some notable Collins employees at the dinner, and as you might expect - being in Dallas - the crowd was almost 50 % ex Collins employees. I will leave the details to the report to follow, but it was a blast..

**Next Year** - California here we come



## Dayton & Dallas 2011 (Cont'd)

**Dayton 2011 Report:** First, the Hamvention itself was amazing. There was a lot of really great Collins gear out in the swap area. The convention was well attended and there was a lot of equipment going out the door. The prices seemed to me to be reasonable, and in spite of swearing that "I did not need any more Collins gear", a complete TCS set went home with me. Beyond that though, there just was a lot of good condition tube equipment there - in general. I had a great time in spite of not being able to get away from the CCA booth that much.

Out in the swap, there was a good selection of S-Line and also A-Line equipment and it seemed to me that folks were willing to deal.

We had a great time at the booth with a lot of members coming by. We also signed up quite a few new members.



**Figure 1 - Tony Sokol, Past Banquet Chairman, holds down booth duty at the CCA Booth. Nice to have you back Tony!**



**Figure 2 - (L to R) Floyd Soo, W8RO, Bill Wheeler, KODEW & Past President Emeritus, Ted Craven, W5USI, and Kale Gentry, WGOH member**

The Friday night banquet was a huge success. It was a great show with the main guest speaker being Jim Maccanni, W0HUP. Jim was the Manager of the Customer Service Group for the KWM/HF 380 family at Collins and gave a very nice talk on the features of the 380 and the changes that it went through during its time in production. If you are a KWM380 fan, it was a "Don't miss it" talk.

We were also fortunate to have a great display of the TSC-60-5 original prototype HF-80 Shelter that was provided by Jim Stitzinger.

Rod Blocksome, KODAS, gave Jim Macanni a great introduction and welcome and he also provided some introductory background on the development of the HF-80 system. Jim Stitzinger then talked a little about finding and reassembling this prototype. As a sidebar, Jim will be doing a story about his multi-year effort to save this piece of history. This story will appear in the Signal Magazine in a coming issue.

Jim had brought the shelter to the hotel and had it operating out in the grass beside the banquet room area. This active display included the original Gen Set trailer and portable antenna - and it was amazing. We all got a chance to play with it and make contacts on it.

**Dayton & Dallas 2011 (Cont'd)**



**Figure 3 - Rod Blocksome, KODAS (L) introducing the guest speaker for the Friday evening banquet, Jim Macanni, W0HUP, KWM380 Customer Service**



**Figure 4 - Rod Blocksome recounting some of the history of the HF-80 shelter provided by Jim Stitzinger, WA3CEX, Banquet Chair**



**Figure 5 - Time warp. 30 years later, KODAS operates the 1 kW amplifier he developed while working at Collins. Floyd Soo, W8RO, looks on in admiration.**

Jim, I want to particularly thank you for the herculean effort, and what had to be a BIG fuel bill, involved in bringing and operating that display. We also all want to thank you for again organizing and orchestrating, a great CCA Dayton weekend. In spite of some surprises from the hotel, it just was super.

To all the rest of you (beside the Jims and Rod) – Scott Kerr, Ron Freeman, Tony Sokol, Karl Bowman, Ted Craven, Bill Wheeler, Floyd Soo and crew, and others I have missed, thanks for your help. We appreciate it.

Finally, I want to thank all of those who donated items to the drawing of door prizes. They are too numerous to name here, but please see the Dayton 2011 pictures and donors on the CCA website and patronize their wares. I want to particularly thank Jay Roman, past editor of CCA Journal, for his kind donation of the Collins R-390A which was won by George Pagels, K9AAL from Kansas City. Wayne Spring, W6IRD and his wife Sharon, K6IRD made it all the way from California and were kind enough to bring along some of his products for the drawing. Thanks Wayne, and Sharon.

We are already working on the events for next year and they should be equally as much fun, so make your plans early and we hope to see you all there.

All and all, I can not imagine a more fun Dayton. Y'all Come next year.



## Dayton & Dallas 2011 (Cont'd)

**Dallas Ham Comm 2011 Report:** Before getting into the report, a couple of words about the Dallas Ham Comm Team that made this all happen. Three gentlemen were asked if they would help put together the first Dallas CCA get-together. All three said “Yes” and all three refused to lead the group. I wondered what would happen. It was a joy to watch. Nobody seemed to ever be in charge. Inputs to me and from me seemed to be at random. But it all just happened seamlessly. That is what happens when you have three really professional folks stepping up to handle some work.

The team consisted of first, Gene Robinson, N5LDX, past Collins employee, good friend of many years, and long time CCA member. Adding to this somewhat “amorphous” effort was Scott Kerr, KE1RR, and fairly new CCA member and then Dave Meitzen, AA9TT, who has wound up in Dallas after moving into Pete Zilliox’s home including some of Pete’s wonderful collection. (Pete, of course, is our Membership Chairman).

Great job guys, and “Can we talk about next year”? You know - Experience counts and all that.

The dinner was held on Friday night, June 10<sup>th</sup>, at the “On the Border” Mexican restaurant there close to the Ham Comm facility in Plano and they did a great job. The dinner was buffet style and it was really good.

There was an overflow crowd and the restaurant was flexible, fast on their feet, and they soaked up the extra folks with ease. The fantastic thing is that out of the almost 30 folks that were there, 13 of them were ex Collins Radio employees and we found, and made, some great connections. There was much reminiscing to be sure.

There were several highlights of the night. Warren Bruene, W0OLY, and his daughter came to the dinner, and Warren was awarded a lifetime membership in the CCA and an award for excellence in his engineering career. He seemed very pleased and, after the dinner, there was a nice crowd around Warren wanting to get to know him better. In addition, Rod Blocksome, K0DAS, and the Project Lead on several of the key HF-80 boxes at Collins Radio, was there and gave a nice talk on the development of the HF-80 family .... and that led up to Jim Stitzinger talking about the finding and restoration of his TSC-60-5 HF-80 Shelter Prototype that he also pulled into the Dallas area for display and operation. Both presentations were fantastic. It is going to be hard to top that one.



The dinner was closed out with a general story telling social time that I will not forget. At the Ham Comm itself, we had a booth set up like we do at Dayton and there was good attendance considering that the Ham Comm attendance itself was way off due to the overlapping ARRL convention that soaked up all the inside floor space. Next year will be better.

All & all, we had a great time and it will happen again next year along with another expansion event in California if all goes well.

**Left: Gene Robinson chats with Warren Bruene after the dinner**

## Understanding AGC & S Meter (Cont'd)

Introduction by Bill Carns, N7OTQ

One would be hard pressed to count the number of threads on the reflector that relate to S-Meter performance, operation, adjustment, related AGC function, and possible modifications to “improve” the AGC performance in Collins equipment.

Although I personally am pretty happy with the AGC performance of most of my Collins gear, there is certainly a lot of interest, misunderstanding and diverging opinions, on this subject in general. I also must admit, as most of you know by now, to being a purist and generally not in favor of any modifications unless they address potential reliability or stability problems. In my opinion, there are few of these.

Noteworthy is the fact that there are many AGC mods out there for various pieces of gear that I would consider technically unsound. So, buyer beware. But, over the last several months, an idea for a series of articles has been germinating that has now been fleshed out. Starting in this issue, there will be a series of feature, or Service Line, articles which delve into this subject. The hope is that you all will gain some understanding of the issues involved and also the relevancy, or appropriateness, of some of the modifications offered now and in the past.

We will not try here to evaluate specific mods. But we will try to prepare you to understand the subject more and then do your own evaluation.

The first Article (in this issue) is written by Don Jackson. Don has written for the *Signal Magazine* before and I am sure most of you are familiar with his work. He is actively working in the field of receiver design and is well qualified to address this subject. A bio on Don has appeared in several past issues..

Some of you that do not have a math or engineering background may be reticent to tie into this first article on AGC theory and function. I would encourage you to screw up your courage and wade in. It is not as bad as it looks and the required take-away from this article is not necessarily the math or equations themselves, but just a general understanding of what the issues are, and how AGC really works. Trust me, if you make the attempt, this understanding will follow.

Due to its comprehensive content, Don’s article has been broken into two parts. The first part relates to general function and static performance. The second is a nice theoretical and active model analysis of what happens under more typical dynamic conditions. You really need the two halves to get a good understanding of what AGC is, and how it works. These two works will also help you to understand whether a modification that you are considering will work for you in a particular situation.

My thanks go to Don Jackson for a great contribution (as usual). He put a lot of work into this article, specially the dynamic Part II, and we appreciate it a lot. Enjoy!

Over the next four issues we will cover AGC, S Meter and AGC operation as well as Adjustments.

# Automatic Gain Control Theory and Application

## Part 1 – Steady State Analysis

By Don Jackson, W5QN

### Automatic Gain Control Theory and Application Part 1 – Steady State Analysis

#### I. Introduction

The purpose of this article is to take some of the mystery out of Automatic Gain Control circuits and their operation. AGC (or AVC) is used in receivers to maintain a reasonably constant output over a wide range of input level. Typical vintage receiver AGC circuitry is an analog feedback system in which the IF output level is detected, compared to a reference voltage, and fed back to the gain control stages. Time constants are incorporated to achieve the desired behavior for different modulation modes.

#### II. The Steady State Model

Part 1 of this article discusses how an AGC loop functions in a “steady state” condition. By this I mean that the input level does not change over the time frame of interest. As background, let’s start with a classic linear feedback system that will be familiar to some. A classical feedback system typically looks like the one shown in the block diagram of Figure 1 below.

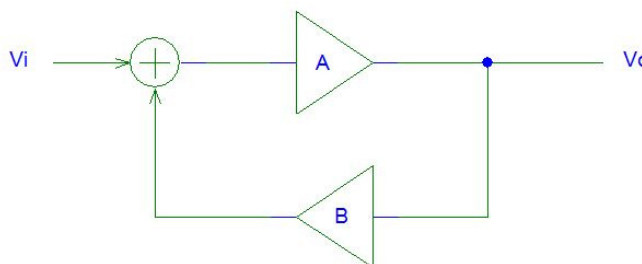

Figure 1 – Basic Linear Feedback

In this diagram, “A” is the forward voltage gain, and “B” is the feedback gain. Normally, “B” is negative so that when summed with the input signal, the output level, Vo, is reduced. The output of such a system is related to its input by the equation:

$$V_o = \frac{V_{in}A}{1-AB}$$

Note that if AB is much greater than 1, the relationship approximates to:

$$V_o \approx \frac{V_{in}}{-B}$$

However, this does not accurately represent a typical receiver AGC circuit for a number of reasons. The first is that the above example describes a linear system, whereas a receiver AGC system is non-linear due to the “threshold” characteristic that is typically part of the receiver AGC design. The threshold circuitry causes the system to operate “open loop” (no feedback) when the IF output level is less than the threshold level, but “closed loop” (feedback is applied) when the output level exceeds the thresh-

## AGC Theory - Part 1 Steady State Analysis (Cont'd)

by Don Jackson, W5QN

old. A feedback system that includes a threshold voltage is shown in Figure 2 below.

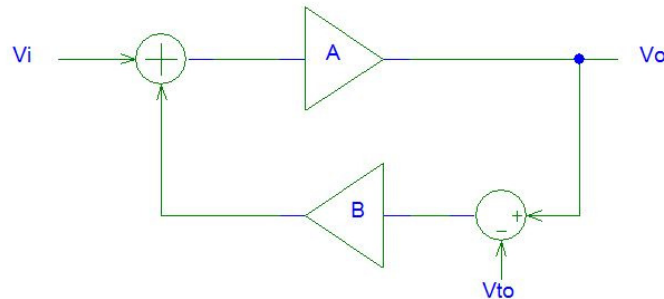

**Figure 2 - Linear Feedback with Threshold**

The threshold level is commonly referenced to the receiver input, but can also be referenced to the output. In order to distinguish the two, we will let  $V_{ti}$  be the input-referenced value and  $V_{to}$  the output-referenced value. In practice  $V_{ti}$  equals  $V_{to}/A$ , where  $A$  is the maximum voltage gain of the receiver from RF input to the AGC detector input.

Because the AGC system is non-linear, we must consider it as having two distinct regions of operation. The first region is where the IF output level,  $V_o$ , is less than the output threshold level  $V_{to}$ . In this mode, there is no feedback and  $V_o$  is simply:

$$V_o = AV_{in}$$

The second region applies when  $V_o$  is greater than  $V_{to}$ . In this mode,  $V_o$  is related to  $V_{in}$  in the following way:

$$V_o = \frac{A(V_{in} - BV_{to})}{1 - AB}$$

If the assumption is again made that  $AB$  is much greater than 1, the relationship approximates to:

$$V_o \approx \frac{V_{in} - BV_{to}}{-B}$$

If  $BV_{to} \gg V_{in}$ , (nearly always the case in a receiver) the above equation can be further simplified to:

$$V_o \approx V_{to}$$

Interestingly, this is exactly what we want in an AGC loop. Unfortunately, this type system is seldom ever seen because the additive method of gain reduction is not very practical due to its low dynamic range performance, and the difficulty of adding AC signals of differing (RF and IF) frequencies.

This brings us to the second item that differentiates the typical AGC feedback system from the classic linear feedback system, which is the way in which the feedback signal is applied to the input. In a classic linear system the feedback is subtracted from the input signal in order to reduce the output level. However, the typical receiver AGC system multiplies the input signal by a function,  $M$ , of the feedback signal in order to reduce the output level. The multiplier is usually an exponential function of the AGC feedback voltage. Vacuum tubes used as gain control devices naturally have this characteristic. An additional parameter that makes the theoretical model more similar to a "real world" receiver is an AGC offset voltage,  $V_{off}$ .  $V_{off}$  is the receiver AGC voltage when  $V_o$  is less than  $V_{to}$ . Additionally, an AGC



## AGC Theory - Part 1 Steady State Analysis (Cont'd)

by Don Jackson, W5QN

Detector function is required since the primary signal path is an AC signal, while the feedback (V<sub>agc</sub>) is DC. The detector converts the IF signal to a DC voltage, solving the AC voltage summing problem of the classic feedback system. The block diagram of a typical AGC feedback circuit usually looks something like that of Figure 3 below.

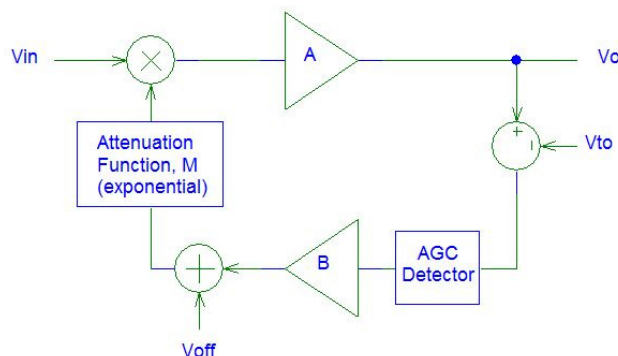

Figure 3 - AGC Block Diagram

Deriving the “closed loop” Vin vs. Vo equations for the AGC circuit of Figure 3 is complex, due to the exponential functions involved. When Vo is less than Vto, the relationship is the same as in all cases where the loop is open:

$$V_o = AV_i \quad \text{(Equation 1)}$$

The equation relating the various parameters for the closed loop case (output Vo greater than threshold Vto) is:

$$V_i = \frac{V_o}{A \cdot 10^{[S/20] \cdot (V_o - V_{to})}} \quad \text{(Equation 2)}$$

where:

S = “open loop” slope of the AGC attenuation curve, in dB/volt, used to calculate M

A = maximum RF to IF receiver gain, which occurs when Vo is less than Vto

Vo = peak IF output voltage at the AGC detector input

Vin = peak RF voltage at the receiver input

B = feedback gain

Note that this equation calculates Vin rather than Vo. The reason for this is that the equation for Vin is what mathematicians term a “transcendental” function. For us, this means it is not possible to solve the equation for Vo using algebraic methods. Nevertheless, it is easy to create the desired results by assuming Vo and calculating the Vin that generated it. Also, it is interesting to note that Voff disappears from the equation when Vo is above the threshold.

The receiver AGC voltage, V<sub>agc</sub>, can be calculated as well. When Vo is less than Vto, the relationship is simply:

$$V_{agc} = V_{off} \quad \text{(Equation 3)}$$

When Vo is greater than Vto, the equation is:

## AGC Theory - Part 1 Steady State Analysis (Cont'd)

by Don Jackson, W5QN

$$V_{agc} = -B(V_o - V_{to}) + V_{off} \quad \text{(Equation 4)}$$

Equations 1 through 4 are our “closed loop equations” used to predict the steady state behavior of our AGC system. In addition to this mathematical model, we will also use a Spice simulator to model the AGC system. Both produce virtually identical steady state results, but the Spice model is required for Part 2 of the article to investigate transient behavior of the AGC loop.

### III. Determining AGC Parameters Experimentally

A number of methods may be used to estimate the parameters of a receiver. An examination of the 75S-3B (and other S-Line receivers) schematic shows the output AGC threshold,  $V_{to}$ , is determined by the cathode voltage at V9, (+2.7 VDC) and the nominal AGC voltage with zero input signal,  $V_{off}$  (-.8 VDC). The values of R33, R55, RF Gain pot R56 (set to maximum gain) and the -65 V bias supply determine  $V_{off}$ . The difference between +2.7V and  $V_{off}$  is 3.5 VDC, the value of  $V_{to}$ , which is not adjustable. When the peak IF voltage at the AGC detector input reaches 3.5 V, the AGC detector portion of V9 begins to conduct, forcing the AGC voltage more negative. The receiver operates in a purely linear manner until the IF output voltage reaches this 3.5 V-peak threshold,  $V_{to}$ . The input referred threshold,  $V_{ti}$ , can be estimated by increasing the receiver RF input (VRMS) until the S-Meter just begins to move. Multiply this RMS input voltage by 1.414 to obtain  $V_{ti}$ , which, by our definition, is a peak voltage. To calculate the maximum RF to IF receiver gain, A, divide  $V_{to}$  by  $V_{ti}$ . Of course,  $V_{ti}$  can be converted to RMS voltage or Pin in dBm if desired. Given that the value of  $V_{to}$  is 3.5 V, and a typical value for  $V_{ti}$  is 1.414uV-pk (1uVRMS) for the S-Line, we can calculate  $A = V_{to}/V_{ti}$  to be approximately 2.5E6. The IF Gain pot, R57, provides for adjustment of A.

A more exact method of determining all necessary parameters (A, S, B,  $V_{to}$  and  $V_{off}$ ) can be obtained by measuring AGC voltage and IF output voltage for a range of RF inputs from below threshold (maybe start at -120 dBm) to perhaps -50 dBm. Connect the DC probe of a HP410B/C to the AGC line (junction of R19 and R60), and the AC probe to terminal 3 of T6. It is then easy to flip the HP410B back and forth for the DC to AC measurements. From this data, you can create a graph of gain reduction (in dB) vs.  $V_{agc}$ , and  $V_{agc}$  vs.  $V_{out}$ , which is the AGC detector characteristic. Figures 4 and 5 are plots generated for my 75S-3B.

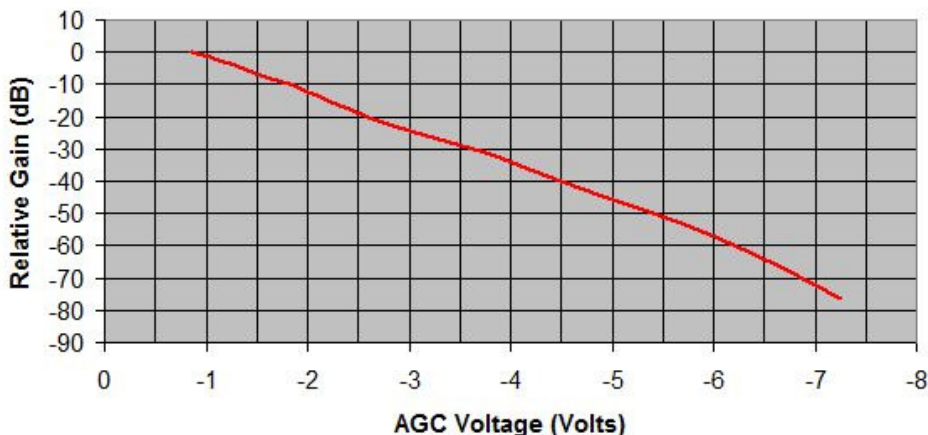

Figure 4 - AGC Relative Gain Curve

AGC Theory - Part 1 Steady State Analysis (Cont'd)

by Don Jackson, W5QN

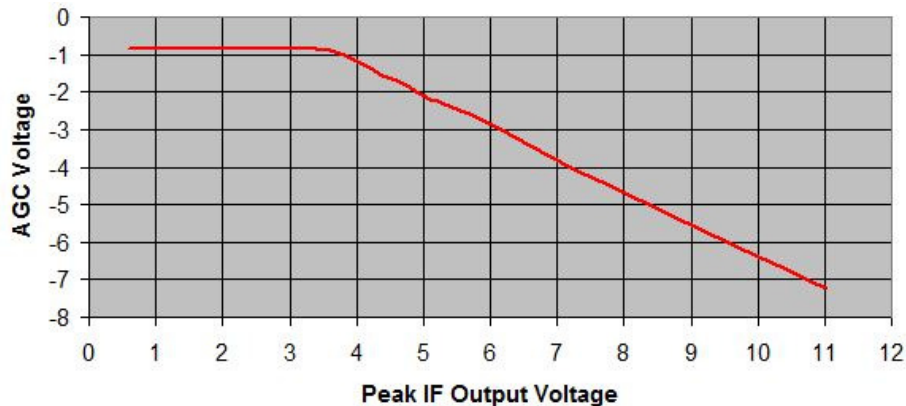

Figure 5 - AGC Detector Gain

The average slope of the Figure 4 is S (dB/Volt), and the slope of Figure 5 is B. Voff is easy to see, since it is Vagc with no signal applied. Vto is the IF output voltage when Vagc just starts to move from its Voff value. From these graphs, S for my receiver is approximately -11.1 dB/Volt, while B is .88. Care must be taken to achieve valid measurements. You need a signal generator with reasonably accurate output power calibration. You also must make both DC and AC measurements with an HP410B or equivalent. Typical test equipment (for example a typical 10:1 scope probe or 10Meg voltmeter) will load down the high impedance AGC line or detune the IF output measurement point at T6. You should also place the receiver in AM mode. On my receiver I noticed about .4 VRMS of BFO leakage appearing at the IF output in SSB/CW mode, which compromised the accuracy of my Vout measurements. Looking at the 75S-3B schematic, I suspect this is normal. Performing the measurements in AM mode turns off the BFO, eliminating this problem.

IV. Plotting Results

We can graph various data sets to get a visual feel for how various parameters affect the behavior of the receiver. For example, let's set maximum receiver gain A=2.5E6, AGC slope S= -12 dB/Volt, output threshold Vto=3.5 Volt, and AGC offset Voff = -.8 Volt. With these settings we can calculate the behavior of the receiver for different values of the feedback gain, B. Figure 6 shows how the receiver output, Vo, varies with input Pin, while Figure 7 shows how the AGC voltage, Vagc, varies. Although receivers may have positively sloped AGC curves or negatively sloped curves, the S-Line receivers and most vac-

Figure 6 - Vo for Different Feedback Gain B

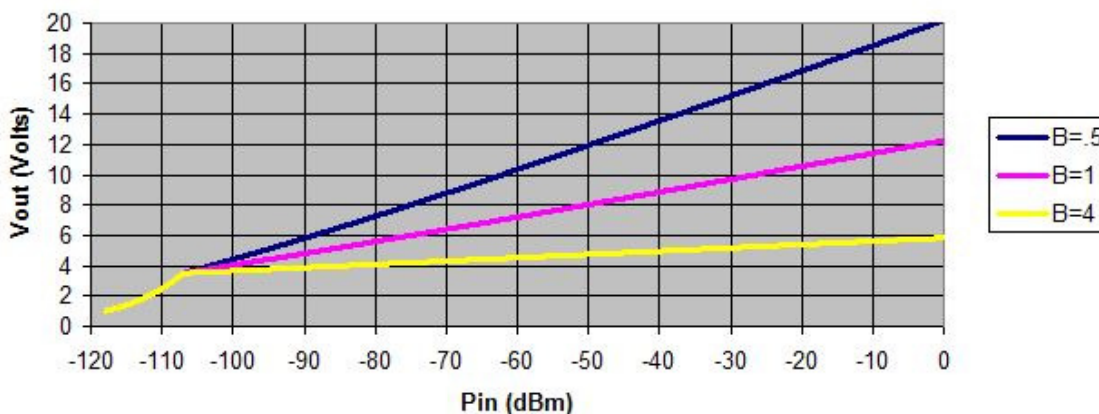



### AGC Theory - Part 1 Steady State Analysis (Cont'd)

uum tube receivers have the negative slope.

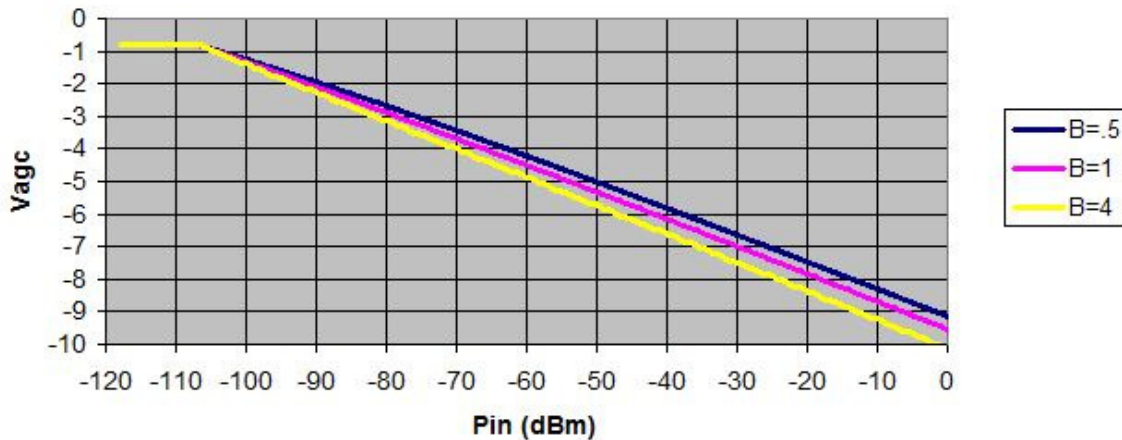

Figure 7 – Vagc for Different Feedback Gain B

Looking at Figures 6 and 7, we can see that increasing B has little affect on the AGC curve, but has a great deal of affect on how well  $V_o$  is held constant as input level is changed. The larger the value of B, the closer  $V_o$  is held to  $V_{to}$ .

Similarly, we can observe what happens when all parameters are held constant except the AGC gain slope, S. These results are shown in Figures 8 and 9.

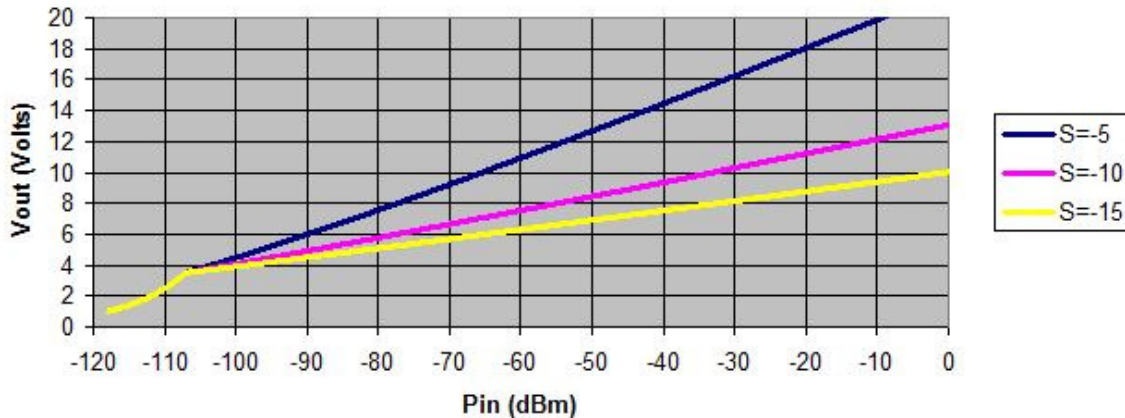

Figure 8 –  $V_o$  for Different AGC Gain Slope S

From Figures 8 and 9 we can see that changing S has a significant affect on both the  $V_o$  and  $V_{agc}$  curves. Since the S-Meter in our receivers is driven by the  $V_{agc}$  voltage, we can see that a larger S would create a higher dB/S-Unit scale factor.

Changing the maximum receiver gain, A, doesn't change the shape of either curve at all. It merely moves the  $V_o$  and  $V_{agc}$  curves to the right or left on the Pin axis. Changing  $V_{off}$  does not change the shape of the curves either. It moves the  $V_{agc}$  curve up or down along the vertical axis, and has no affect at all on the  $V_o$  curve.

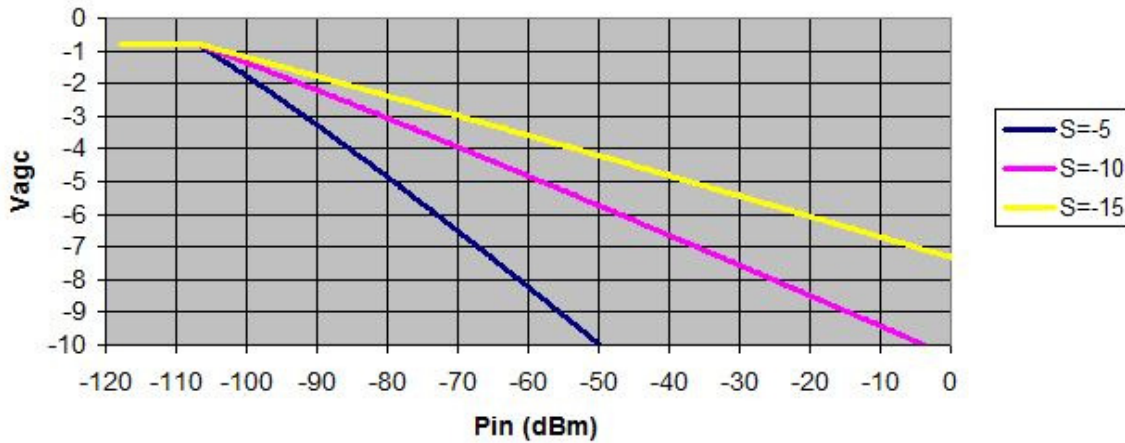

Figure 9 - Vagc for Different AGC Gain Slope S

## V. Comparing Measured Data to the Theoretical Models

To demonstrate the validity of the theoretical models used, let's compare some actual measured data taken on my own 75S-3B. Figure 10 shows a comparison of the AGC curve of the theoretical models (closed loop equations and Spice simulation) with the actual receiver. Plots are shown for two cases of the closed loop equation model. One calculation assumes an ideal AGC peak detector with  $B=1$ , and the other uses  $B=.88$ , which corresponds to my 75S-3B measured value.

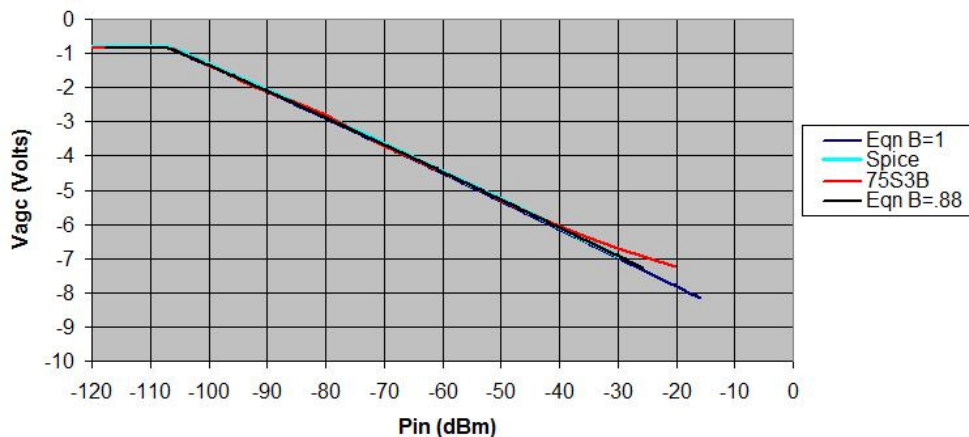

Figure 10 - Theoretical vs. Measured Vagc vs. Pin

The four data sets of Figure 10 are in remarkable agreement. As you might expect, the model based on the closed loop equations and the Spice circuit model are essentially identical. The Spice model is similar to a schematic on the computer, but if we have derived our equations correctly, the results should be the same as the equations. The only significant difference between these two theoretical models is that the Spice model includes an approximation of the 6AT6 tube to model the AGC detector, whereas the equations assume a perfect peak detector. This produces little difference in the results, however. In both these models the AGC parameters A,  $V_{to}$ , and S are determined by direct measurement of my 75S-3B receiver. The good match of the curves is a testament to the consistency of S, which remains reasonably close to -11.1 dB/Volt over a wide input dynamic range in the 75S-3B. Note that S is a strong function of the variable gain characteristics of V2, V6 and V7, so it is expected that different

## AGC Theory - Part 1 Steady State Analysis (Cont'd)

receivers will perform somewhat differently. Another factor is the grid current drawn by these three tubes, which can affect the value of  $V_{off}$ . As we have already seen, changes in  $B$  have only a small affect on the AGC curve, and that is reflected in Figure 10.

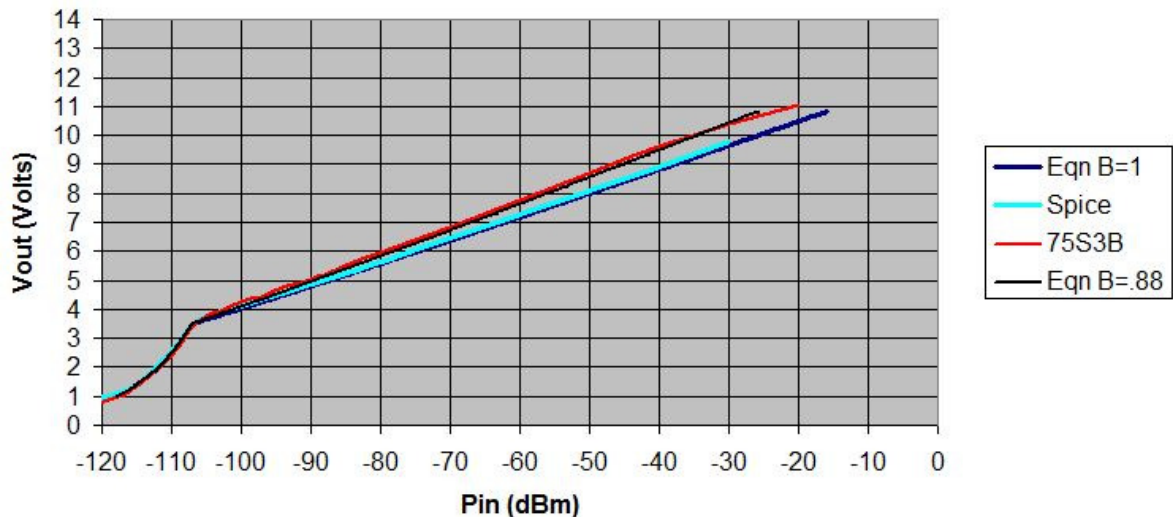

Figure 11 - Theoretical vs. Measured Vout vs. Pin

The plots in Figure 11 also match quite well. Note that the plot for the closed loop equation model “Eqn B=1” is a very close match to the Spice model plot, which it should be. When the closed loop equation model is modified to change  $B$  to the 75S-3B measured value of .88, that plot matches well with the actual 75S-3B plot. All things considered, the theoretical models and the actual measured data agree quite well.

### VI. Conclusions and Comments

An AGC loop is a feedback system that attempts to hold the receiver output constant over a wide range of input level. The system has an output threshold,  $V_{to}$ , which determines when the AGC loop begins to function, as well as the approximate receiver IF output level under closed loop condition. How close the AGC loop holds the output to  $V_{to}$  is determined by the feedback gain  $B$ , which is set by the AGC detector gain in the 75S-3B. With appropriate measurement of parameters, we can predict the steady state behavior of the AGC system.

A term occasionally in used in AGC discussions is “delayed AGC”. This term actually refers to an AGC system with one or more thresholds. I find the term confusing since we usually associate a “delay” with time. In this case, “delay” refers to input power. As in, the AGC control action is “delayed” until the input power reaches a specified level or threshold. In modern receivers, there are often multiple thresholds, each controlling the gain of a different stage in order to optimize noise figure and distortion over the entire range of RF input levels.

Part 2 of this article will analyze the transient characteristics of the AGC loop. The transient analysis is more complex and addresses the loop behavior with rapid “step function” inputs. We will look at the circuitry in the 75S-3B and analyze how it functions to control the transient behavior.

Questions and comments on any aspect of this article are encouraged. Hopefully, this article will provide a better general understanding of receiver AGC systems.

Cheers, Don W5QN



## Remembering CCA Members Lost This Past Year \*

### **K7ER, Elliott Klein - August 1, 2010**

Born March 23, 1949 in New York, Elliott's family moved him to Arizona when he was just 6 years old. By 12 years old, he became somewhat of a celebrity by being busted for running a first class (according to the FCC) quality pirate AM broadcast station. Encouraged by the FCC, Elliott went on to become, first, a top market DJ in Phoenix, AZ., then a qualified station engineer of some repute, then a degreed Electrical Engineer and finally a very successful telecommunication consultant. During his career, he became the Consulting Station Engineer for Buck Owens' media group and found great success with his software enhanced station optimization work. In 1980, he got his Extra Class License as K7ER and started, what became, a formidable Collins Collection. Elliott never did anything in a small way. He was a long term supporter and member of the CCA and also a close personal friend.



### **N9BUU, John Raitt—July 7, 2010**

Born in Chicago in 1924, John served in the US Army in WW II in Europe. Following the war, he pursued a career as a musician attaining renown as a bassoonist for the Chicago Symphony under Fritz Reiner and Sir George Solti. He was also an accomplished technician, mastering double reed making for wind instruments and writing several papers on this subject. Also a ham, N9BUU, John wrote several articles for his Collins Collectors friends and served as net control on a number of nets over the years. A well know voice on the bands, John is missed by all. John was also an active MARS member, serving until his death. No picture available. John is survived by his four children and three grandchildren.

### **W7YO, Gary Leininger - January 1, 2011**

Born in Buffalo, NY on July 7, 1952, Gary was just 58 at the time of his passing as a result of a brain tumor. He obtained a BA Degree in Psychology followed by an MS in Criminal Justice. He went on to found the first Crime Lab for the St. Cloud, MN Police Dept. Following his further education at the FBI Academy as a Latent Finger Print Expert, Gary worked for the SCPD until his health failed him. He was known for his meticulous nature and his high work ethic. Gary was a long time ham radio operator and supporter of the CCA and has held several officers positions in the past. He was also very active and a well know participant in the nets - serving as net control for the 75 meter net at several times. Gary also served his country in CID in the US Army. He was survived by his wife, 2 children and 3 grandchildren.



### **K9JCB, Lynn Stewart - January 8, 2011**

Lynn was born in Pittsburg, Kansas on December 31, 1946. He served honorably in the US Navy during the Vietnam war, where he was disabled. Following his service there, he earned a Electrical Engineering Degree and worked in international positions most of his life. He was an avid gun collector and loved classic cars, his motorcycling and ham radio. He was a long time member of the CCA and religiously chose his S-Line for his contacts over his more modern gear. Lynn was often heard on our nets and he is missed.

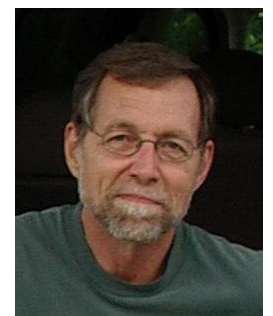

\* Editor's Note: Please advise us if we have missed some of our SK friends.

## From the President



What an active quarter we had this past quarter. I am pleased to say that membership continues to increase in spite of our stagnant economy, and the recent new event at Dallas Ham Comm was a wonderful experience and, by all accounts, a great success.

As most of you know, we transitioned to two new board members in Q1 and these new folks have hit the ground running and are contributing big time. My thanks to both of you, Karl and Ron.

The details are in the included story in this issue, but suffice to say here that we had a great Dayton Hamvention with close to a record number of attendees at the banquet on Friday night. The booth was very active with good new member sign-up and there were a lot of old faces there to enjoy. I don't know about all of you, but I go to Dayton, and now Dallas, to see old friends that I normally only get to talk with on the air.

I have also noted with interest this past quarter that there are a continuing number of new younger S-Line (as well as other types) enthusiasts looking for guidance from this magazine and from the reflector. We will try and respond with help and guidance from the older set here and also with resources on the website and the reflector.

I want to comment here about a sad subject. These last two quarters have been very devastating as far as the death of our some of our members. It is impossible to write articles about all of them. I wish I could. In some cases, sadly, I did not know them well. In others, I did know them well and I, in one case, can't even bring myself to approach the job. We were very close. I have attempted to make a list with comments here in this issue. Please forgive me if I have missed anyone.

I want to finally apologize for the lateness of this issue. It was my fault. Following the Dayton Hamvention, I came down with a very bad flu, as did several other members. Mine went into a serious bronchial infection that proved to drug resistant and I am still battling it over a month later. I just have no energy. I am gaining on it and getting some of the weight back, but it is slow going. I hope that all of you have fared better!

That's it for now, and have a great quarter! We will see you all on the nets I hope. Best 73s to all.

de Bill, N7OTQ - Contact [wcarns@austin.rr.com](mailto:wcarns@austin.rr.com)

## Editors Desk (Cont'd)

unexpected passing of my good friend Elliott Klein, K7ER. Then, there followed a number of others. The death of Elliott hit all of us that knew him very hard. He was only 61 and it was not his time. In this issue, I am trying to come to grips with this and get caught up. I know for a fact that I have missed several others, so will all of you help and, if you know of the loss of other members this past year, will you let me know and I will include them next quarter.

Have a wonderful quarter and best 73s,

Bill, N7OTQ

The **Signal Magazine** is published quarterly by The Collins Collectors Association Copyright© 2011, all rights reserved.

**Editor** Bill Carns, N7OTQ  
**Co-Editor,** Joe Nyberg, W1LJN

### Board of Directors

Bill Carns, N7OTQ	President
TBD,	Vice Pres.
Jim Stitzinger, WA3CEX,	Secretary
Bill Wheeler, KODEW,	PR
Karl Bowman, W4CHX	Events
Ron Freeman, K5MM	Treasurer

*The CCA is licensed by Rockwell Collins to reproduce and disseminate Collins copyrighted documents related to Collins amateur radio products.*

The Collins Collectors Association  
P.O. Box 1269  
Wimberley, TX 78676-1269

[www.collinsradio.org](http://www.collinsradio.org)